

BULETINUL INSTITUTULUI POLITEHNIC DIN IAȘI
Publicat de
Universitatea Tehnică „Gheorghe Asachi” din Iași
Volumul 63 (67), Numărul 1, 2017
Secția
CONSTRUCȚII DE MAȘINI

PORTABLE DEVICE FOR CONTROL OF INNER CYLINDRICAL SURFACES - THE COAXIALITY PARTICULAR CASE

BY

ADRIANA MUNTEANU*, FLORENTIN CIOATĂ and CRISTIAN COBZARU

“Gheorghe Asachi” Technical University of Iași,
Faculty of Machine Manufacturing and Industrial Management

Received: December 15, 2016

Accepted for publication: September 15, 2017

Abstract. One of the most complex and difficult tasks regarding the geometrical tolerances is the measurement of coaxial deviation of inner cylindrical features. The paper addresses the difficulties met in the evaluation of coaxiality tolerances and starting from the idea that the exact methods are difficult to implement but also complex and expensive. Instead verification methods for checking coaxiality with mandrel control or plugs are easy to apply but does not offer accuracy regarding the results and are in the impossibility of obtained validation, the portable methods for measuring either do not provide the accuracy required or are time consuming and adjusting processing machine payoffs is very high. This paper presents a portable device capable of providing precision but to be easy to handle and adjust.

Keywords: coaxial deviation; portable device; selfcentering device.

1. Introduction

Concentricity and coaxiality deviations are a part of surfaces relative position deviations, which together with guidance deviations, determine the

*Corresponding author; *e-mail*: adycypmunteanu@yahoo.com

orientation and accuracy of relative position of geometric elements of machine features.

Deviation from coaxiality represents the maximum distance between the real adjacent rotation axis of considered surface and the datum axis measured within the reference length. The datum axis can be the rotation axis of other adjacent surfaces or the common axis of multiple rotation adjacent surfaces (Xuebao, 2009). In case of the machine parts joints with outer and inner rotating surfaces, coaxial deviations of the mounting surface constitute a decisive factor in the correct combination of joint parts and of the assembly functioning at the specified parameters (Kaisarlis *et al.*, 2011; Gherghel and Seghedin, 2006).

In the shaft piece type case, the coaxiality deviation of inner surfaces determines the incorrect position of fitted parts and during the operation these items will rotate eccentrically.

Measurement of coaxiality deviation of the inner cylindrical surfaces, sleeve type pieces, is generally performed using stationary devices, equipped with indicating instruments; when a portable equipment is required, there are necessary mechanisms and centering elements on the inner cylindrical surface, specified as given.

The coaxiality deviation control of inner cylindrical surfaces of the holes, in carcasses (frame) case, is achieved by testing and measuring using distinct control methods (Seghedin, 2006) briefly presented in Fig. 1.

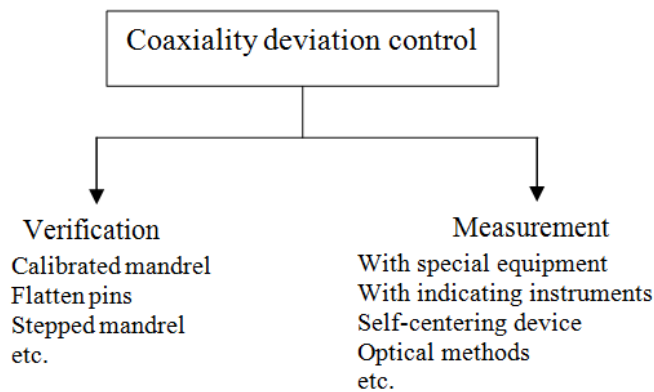

Fig. 1 – Methods for coaxiality deviation control.

Taking in consideration the analysis of the methods for measuring coaxial deviation of the inner cylindrical surfaces, socket type parts, namely, carcasses, the following conclusions could be emphasized (Demian, 1980; Mircea, 2004; Seghedin, 2006):

- the precise measurement methods are difficult to implement in case of the stationary control means and require a complex and costly range of measuring instruments and accessories;

- the verification methods with pins or testing mandrel are easy to apply, but do not provide appropriate verification accuracy, leading to irrelevant results of the verification, especially in the case of carcasses with large distances between walls (Drăghici *et al.*, 1981; Sturzu, 1977);
- the measurement methods that use portable devices either do not provide adequate accuracy or are time-consuming regarding adjustment, measurement and processing of measurement results.

2. Schematic Diagram of the Portable Device

To establish a method of measuring the deviation from coaxiality, it was considered its definition, as the maximum distance between the axis of the inner considered cylindrical surface and the axis of cylindrical inner pair, specified as datum axis, measured within the reference length. Thus, a method characterized by the following elements was considered (ISO System Standard; Dimensional Engineering, Based on the ASME Y14.5M-1994):

- Materialization of inner cylindrical surface axis specified as datum axis;
- Materialization of tolerated axis of cylindrical inner surface (pair surface);
- Measuring the distance between the two axes materialized (Coaxiality Tolerance, available at: <https://books.google.ro/books>, 2016).

To measure the deviation from coaxiality, the materialization of the axes of the two inner cylindrical surfaces is required (Fig. 2). For this purpose, a contact could be achieved among the inner cylindrical surfaces a and b , the levers 2 and 3, which move in radial direction with the same distance (movement III), in bearing 4, which can be locked with locking screws 5. Each support can move on the cylindrical rods 6 and 7 (movement II) and locks in the desired position by locking screws.

In this way, it materializes the axes of the two inner cylindrical surfaces a and b , which coincide with the axes of cylindrical rods 6 and 7. On the cylindrical rod 6, there is mounted the support 8 of the indicating instrument 9, whose measuring tip is placed in contact with the surface c , of a calibrated roller 10. It is mounted to fit with minimum clearance equal to zero on the cylindrical rod 7; thus, calibrated roller axis 10 coincides with the axis of the cylindrical rod 7.

The support 8 of the indicator instrument 9 can rotate without clearance, on the cylindrical rod 6 (rotational movement I). After contacting the feeler with c surface, the indicating instrument (a dial gauge or a digital comparator) is set to zero. It is rotated, then the indicating instrument maintains a permanent contact between the feeler and measured surface c of a calibrated roller 10,

• The deviation from coaxiality measurement can be achieved using controlled workpieces with axes oriented horizontally or vertically.

These conclusions highlighted that the analysis of the presented measurement method are at the same time requirements that must meet the control device presented in this paper.

The essential advantage of the examined devices is the accuracy of centering; the most important disadvantage is that solutions that provide greater accuracy of centering are not covered by a sufficient range values of inner cylindrical surfaces diameter and they are characterized by a high complexity (for example, selfcentering devices with plungers).

In this paper it is proposed as solution a selfcentering mechanism which eliminates the two drawbacks mentioned above, having a medium complexity and providing for a sufficient diameters values range, so that it is characterized by a high degree of universality (Fig. 3).

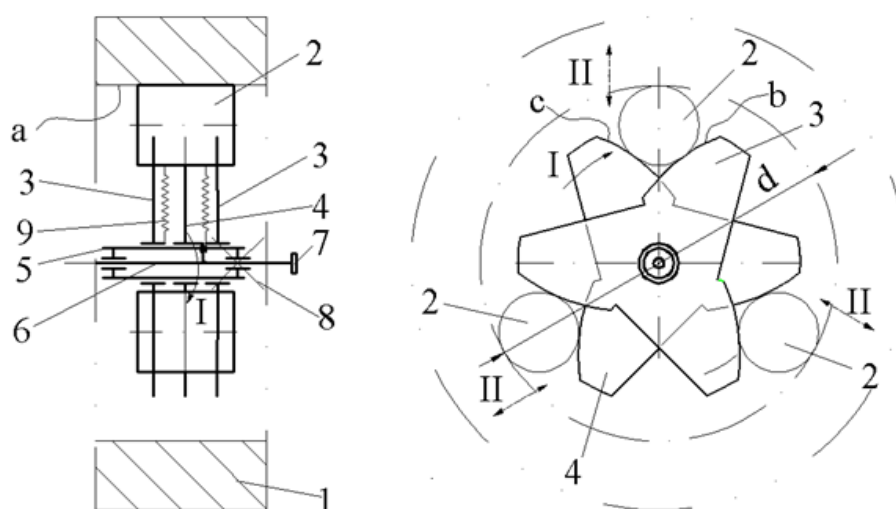

Fig. 3 – Selfcentering mechanism with calibrating rollers.

This mechanism is named selfcentering mechanism with calibrating rollers, because the contact elements with the surface *a* of the workpiece 1, is achieved by three cylindrical rollers 2. The rollers surfaces are made so that they materialize the geometric cylinder (the deviation from cylindricity is minimum). The contact of the calibrated rollers (arranged uniformly on the circumference) with the cylindrical inner surface *a* is performed along their generators. The calibrated rollers are supported by active edges of the profile *b* of the discs 3 and *c* shaped edge of the disc 4. The two discs 3 are mounted on the cylindrical body 5 secured to it, and the disc 4 is also mounted on the

cylindrical body; it is placed between the discs 3. The disc 4 can be moved on the cylindrical body 5 (rotational movement I), in relation to the disk 3, and it is trained in rotation by the shaft 6, driven by handwheel 7 and may be locked in the desired position using the locking screw 8.

By rotation of the disc 4, there is changed the relative position of the active edge profile b and c , on which the two calibrated rollers are leaned and which determines the displacement, in a radial direction, of two calibrated rollers (movement II).

At the mobile disc 4 rotation, the three calibrated rollers 2 move radially with the same distance, so that the generators most distant from the common axis of the discs 3 and 4 of the rollers will materialize an adjacent cylinder whose diameter is variable.

Permanent contact of the calibrated rollers with the active shaped edges of discs 3 and 4 is provided by stretching coil springs 9.

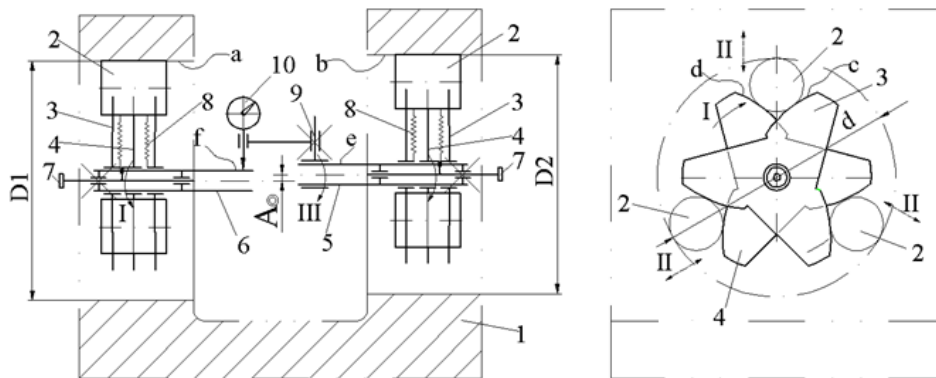

Fig. 4 – Schematic diagram for portable device.

In the present paper, the above mentioned device for coaxial deviation measurement case is particularized. Schematic diagram of the technological device for measuring coaxial deviation from the inner cylindrical surfaces is simple, using two selfcentering mechanisms and a mechanism for the guidance and fixing of the indicator instrument (Fig. 4).

In this case, it is noted that the control device diagram complies with the measurement scheme adopted in Fig. 2. To materialize the axes of inner cylindrical surfaces a and b , there are used two selfcentering mechanisms with calibrated rollers formed by calibrated rollers 2, fix disks 3 and mobile disks 4, cylindrical bodies 5 and 6 with the active surfaces e , respectively f , and the mechanisms of the mobile disc 4 rotation driven by hand wheels 7.

When the two calibrated rollers come into contact with the internal cylindrical surfaces a and b , the active surfaces e and f , of the cylindrical bodies

5 and 6, are coaxial with the corresponding inner cylindrical surface. Thus, one can measure the deviation from coaxiality of the inner surfaces b to a , by measuring the maximum distance between the axes of the active surfaces e and f of the cylindrical bodies. With this aim in view, the active surface f is brought into contact with the feeler of the indicating instrument 10 and the instrument is set to zero. The indicating instrument is fixed to the holder 9, which is mounted on the cylindrical body 5 that can be rotated on the active surface e .

After zeroing, the indicating instrument is rotated, with a full rotation, in permanent contact with the surface f of the cylindrical body 6 and the extreme indications δ_{max} and δ_{min} of the instrument are noted, so that to the coaxiality deviation could be determined.

Deviation from the coaxiality of the axis of cylindrical surface with the axis of the inner surface b , specified as datum, is obtained using the Eq. (1).

3. Portable Device for Measuring the Coaxiality Deviation

Starting from the schematic diagram of the control device above mentioned (Fig. 4) and knowing the requirements that must be fulfilled, it has developed a constructive version of a portable technological device designed to control the coaxial deviation of cylindrical inner surfaces (for bush type workpieces) with diameters in the range from 90 mm to 130 mm (Figs. 5 and 6).

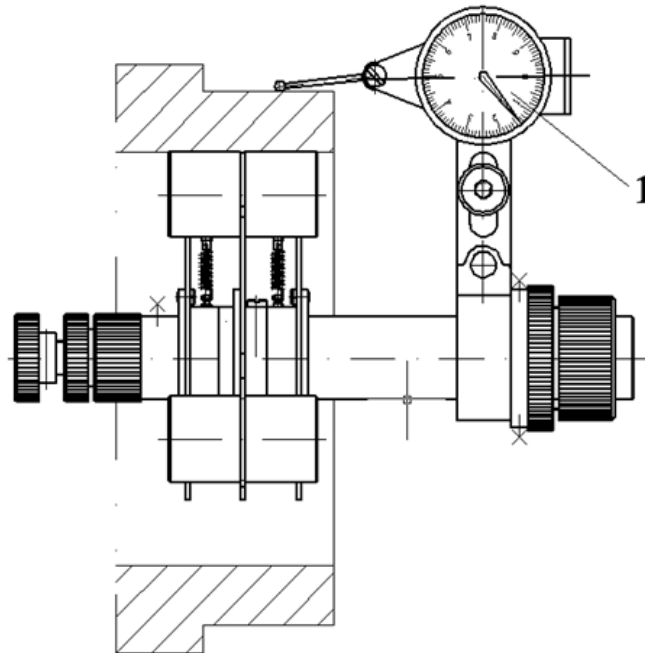

Fig. 5 – Coaxiality control portable device – front view.

Characteristic of this control device is that, being a portable device, all the important components for determining the positioning and orientation of the controlled workpiece, respectively the indicating instrument, are all unitarily integrated into the device body.

The technological device for the control of coaxiality of inner cylindrical surfaces consists of the following distinct subsets:

- The subassembly device of orientation and positioning;
- The measurement subassembly;
- Auxiliary elements and mechanisms.

The first two types of subassembly with the auxiliary elements and mechanisms are mounted on the tubular body of the control device.

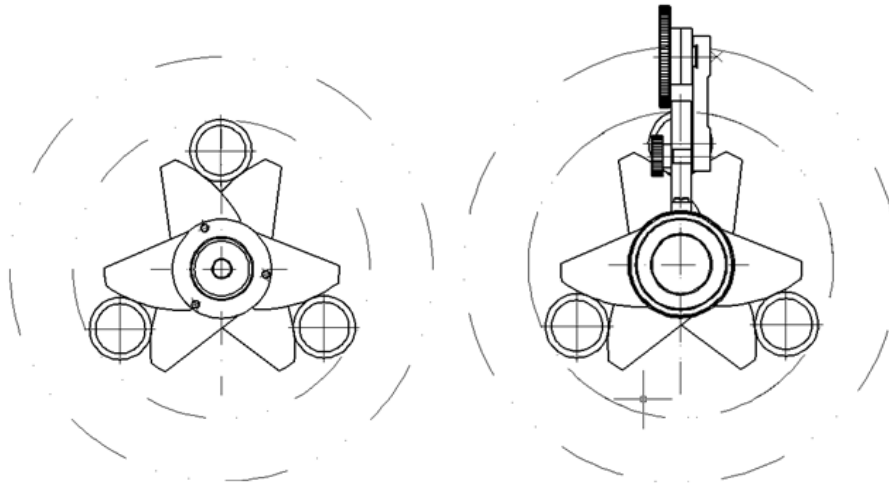

Fig. 6 – Coaxiality control portable device – top view.

The assembly of orientation and positioning of the control device is designed to guide it in relation to the control piece and to position it on the inner cylindrical surface of the workpiece, type sleeve, in order to measure the deviation from coaxiality; simultaneously, this subset materializes the axis of rotation of the adjacent inner cylindrical surface, which will support the measuring device (Fig. 7).

The subset consists of a centering mechanism with calibrated rollers. Centering mechanism comes into contact with the inner cylindrical surface of the workpiece, along three straight lines that are the generators which are most distant from the center of the calibrated rollers 3; in this way, the three straight-line generators, evenly distributed over the circumference of the cylindrical surface, materialize the adjacent cylinder of the measured inner surface which forms the datum axis.

The calibrated rollers rest on the edges of the active profile of the two disks, coming into contact with them, in three points: two points on edges assets of the two fix disks and a contact point on the active edge of a mobile disc.

To prevent axial movement of calibrated rollers to active edges of the fixed disks, on the calibrated cylindrical surface of the rollers is realize a channel, in which is includes the removable disk edge. The permanent contact between the calibrated rollers and the edges of active disks is provided by stretching coil springs (two springs for each roll calibrated).

The assembly for measuring ensures the determination of deviation from coaxiality of the tolerated inner cylindrical surface compared to the datum axis materialized by the orientation and positioning subassembly; this measurement assembly captures the measurement information and sends it to indicator instrument (Fig. 7).

The measurement information is transmitted directly to one indicating instrument (Fig. 7), because the item capture is just the feeler of this instrument; spherical probe of the indicating instrument 1 is brought into contact with the control inner cylindrical surface. It has chosen like indicating instrument, for example a pupitast that can be placed in locations with limited volume, because of its small overall dimensions. This indicating instrument is mounted on an adjustable support so that one can control the fixing height. This support is mounted on the active surface of the cylindrical device body with minimum clearance equal to zero and can perform two movements:

- a movement of rotation round of the axis of the cylindrical body; this movement is achieved during measurement to ensure the crossing of one complete rotation;
- a movement of axial displacement of the active surface of the cylindrical body; this movement is performed to adjust the device so that the probe is brought into the control inner cylindrical surface.

The axial movement, that is achieved when the adjusting device runs, must be blocked during the measurement and with this aim in view, an elasticized sleeve mounted on the cylindrical body was used; this solution with elasticized sleeve was imposed by the necessity of blocking only the axial movement, but to permit freely rotation around the axis of the cylindrical body. Thus, the two assemblies, which forms the device (the mechanism of selfcentering with calibrated rollers and the mechanism of fixing the indicating instrument), are mounted on the same element, namely, its cylindrical body. This fact gives an increased accuracy of the control device measurement, because:

- Arrangement of the three discs, fixed and mobile, in centering mechanism structure on the same cylindrical surface of the device body determines the coincidence of the axis of the adjacent cylinder materialized by calibrated rollers with the axis of the active surface of the cylindrical body;

- Fixing mechanism (displacement) layout of the indicator instrument on the active surface of the cylindrical body determines the instrument rotation around the axis of the adjacent cylinder specified as datum axis.

The measurement technique of the coaxiality deviation is presented in Fig. 7, where 1 is the workpiece, 2 and 2' are calibrated rollers, 4 and 4' are cylindrical bodies, 5, 5', 6 and 6' are adjustment elements, 7 is the indicating instrument feeler, 8 is the indicating instrument, 9 is the fixing support and 10 is bushing cantilever.

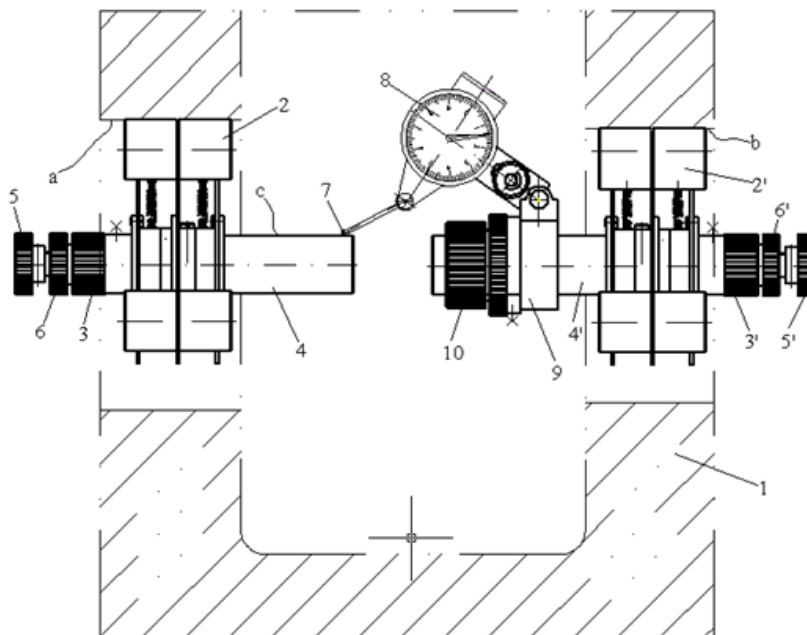

Fig. 7 – Measurement technique.

4. Conclusions

Considering the above mentioned aspects, the aim of this paper was to establish a system of rule checking for device that overcomes the highlighted drawbacks and to combine advantages of stationary devices, characterized by high precision measurement, but that cover a range values for diameters of controlled inner cylindrical surfaces between 90 mm and 130 mm. Thus, the device is based on a new solution of selfcentering mechanism with contact on the inner cylindrical surface. This selfcentering mechanism with calibrated roller mechanism has a great accuracy of materializing the rotation adjacent surfaces.

The portable device presented in present paper has some specific characteristic:

- The possibility of materializing the adjacent cylinder to both the inner cylindrical surface of control, as well as specified datum;
- The possibility of using the parts controlled axis oriented horizontally or vertically;
- The device has a small number of mobile joints, which increases the measurement accuracy;
- The high degree of versatility allows the use in multiple categories of items: fixed or rotating bushing type, skeletal etc.;
- Covers a wide range of diameters of materialized surfaces and ensures a quick adjustment on adjacent cylinder to be materialized;
- It has reduced constructive complexity, with reduced overall dimensions and mass.

The device can maintain the values to which there was safe to be adjusted and easy to be handled, and to ensure fast measurements.

The aim of future research is to study the possibility of using this new device in other types of measurements.

REFERENCES

- Demian T., *Constructive Elements of Fine Mechanics* (in Romanian), Edit. Didactică și Pedagogică, Bucharest, 1980.
- Drăghici I. *et al.*, *Guidelines in Machine Design* (in Romanian), vol. 1 and 2, Bucharest, Edit. Tehnică, 1981.
- Kaisarlis G., Provatidis C., Sfantsikopoulos M., *A New Approach for the Effectiveness of Coaxiality Tolerance Verification*, International Journal of Applied Science and Technology, **4**, 3, 39-49 (2011).
- Gherghel N., Seghedin N., *Conception and Design of Technological Devices Supports* (in Romanian), Iași, Tehnopress Publishing House, 2006.
- Mircea D., *Dimensional Control in Machine Manufacturing* (in Romanian), Iași, Tehnopress Publishing House, 2004.
- Seghedin N., *Technological Devices for Fine Mechanics* (in Romanian), Iași, Tehnopress Publishing House, 2006.
- Sturzu A., *Basics of Research and Design of Control Devices for the Accuracy of form and Position of Surfaces* (in Romanian), Bucharest, Edit. Tehnică, 1977.
- Xuebao G., *Improvement Coaxiality Measurement Method for Transmission Shaft*, Acta Photonica Sinica, **38**, 11, 2932-2936 (2009).
- * ISO System of Tolerances and Fits (Collection of Standards).
- ** *Coaxiality Tolerance*, available at: <https://books.google.ro/books?id=Pw4x1wzBHmoC&pg=PA308&lpg=PA308&dq=coaxiality+tolerance+definition&source=bl&ots=GmucQjE992&sig=VWckToYIXoaS09PJ9gR7RwTSN2c&hl=ro&sa=X&ved=0ahUKEwi7iLWD893RAhWCKiwKHSQWAJY4ChDoAQhAMAU#v=onepage&q=coaxiality%20tolerance%20definition&f=false>, accessed: December 2016.
- ** Dimensional Engineering, Based on the ASME Y14.5M-1994 Dimensioning and Tolerance Standard.

DISPOZITIV PORTABIL PENTRU
CONTROLUL SUPRAFETELOR CILINDRICE INTERIOARE - CAZUL
PARTICULAR AL COAXIALITĂȚII

(Rezumat)

Una dintre sarcinile cele mai complexe și dificile în ceea ce privește toleranțele geometrice este măsurarea abaterilor la coaxialitate ale suprafețelor cilindrice interioare. Lucrarea abordează dificultățile întâmpinate în evaluarea abaterilor la coaxialitate, plecând de la ideea că metodele precise sunt greu de implementat, dar și complexe și scumpe. În schimb, metodele de verificare a coaxialității cu dornuri de control sau cu cepuri sunt ușor de aplicat, dar nu oferă acuratețe, ducând la imposibilitatea validării rezultatelor obținute, iar metodele portabile de măsurare fie nu asigură precizia cerută, fie timpul de reglare și prelucrare a rezultatelor este foarte mare. Se prezintă un dispozitiv portabil capabil să asigure o bună precizie, dar să fie și ușor de manevrat și de reglat.